

PRODUCT:

2835 SURFACE MOUNT LED

FEATURES:

2.8 mm × 3.5 mm × 0.75 mm surface-mount LED
 120° emission angle



DESCRIPTION

The monochromatic 2835 SMD series contains 7 different colors including conventional RGB and additional violet, cyan and lime and amber to achieve an extraordinary wide color gamut and thus is more flexible for sophisticated color combination for applications such as stage effect or accent lighting.

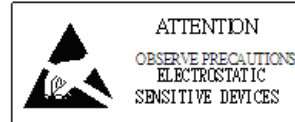

ELECTRICAL-OPTICAL CHARACTERISTICS (T _A = 25 °C)							
PARAMETER	SYMBOL	VALUE			UNIT	TOLERANCE	CONDITION
		MIN.	TYP.	MAX.			
Forward voltage	V _f	1.8	--	2.3	V	±0.05	I _f = 60mA
Luminous flux	Φ _v	--	10	--	lm	--	I _f = 60mA
Dominant wavelength	λ _D	619	--	625	nm	±5	I _f = 60mA
Peak wavelength	λ _P	--	630*	--	nm	±5	I _f = 60mA
Reverse current	I _r	--	--	10	μA	±0.1	V _r = 5V
Viewing angle	2θ _{1/2}	--	120	--	Deg	±5	I _f = 60mA

ABSOLUTE MAXIMUM RATING (T _A = 25 °C)			
PARAMETER	SYMBOL	LIMIT	UNIT
Power Consumption	P _D	360	mW
DC Forward Current (pulsed)**	I _{Fp}	200***	mA
DC Forward Current	I _F	150	mA
Reverse Voltage	V _R	5	V
Junction Temperature	T _j	115	°C
Solder Point Temperature****	T _s	105	°C
Operating Temperature	T _{opr}	-40 ~ +85	°C
Storage Temperature	T _{stg}	-30 ~ +85	°C
Soldering Temperature	T _{sol}	260 ± 5	°C
Reflow Cycles Allowed	--	2	--

* Tolerance of peak wavelength is customizable.
 ** Pulse width ≤ 0.1ms, Duty ≤ 1/10.
 *** Theoretical data.
 **** See page 3 for solder point definition.

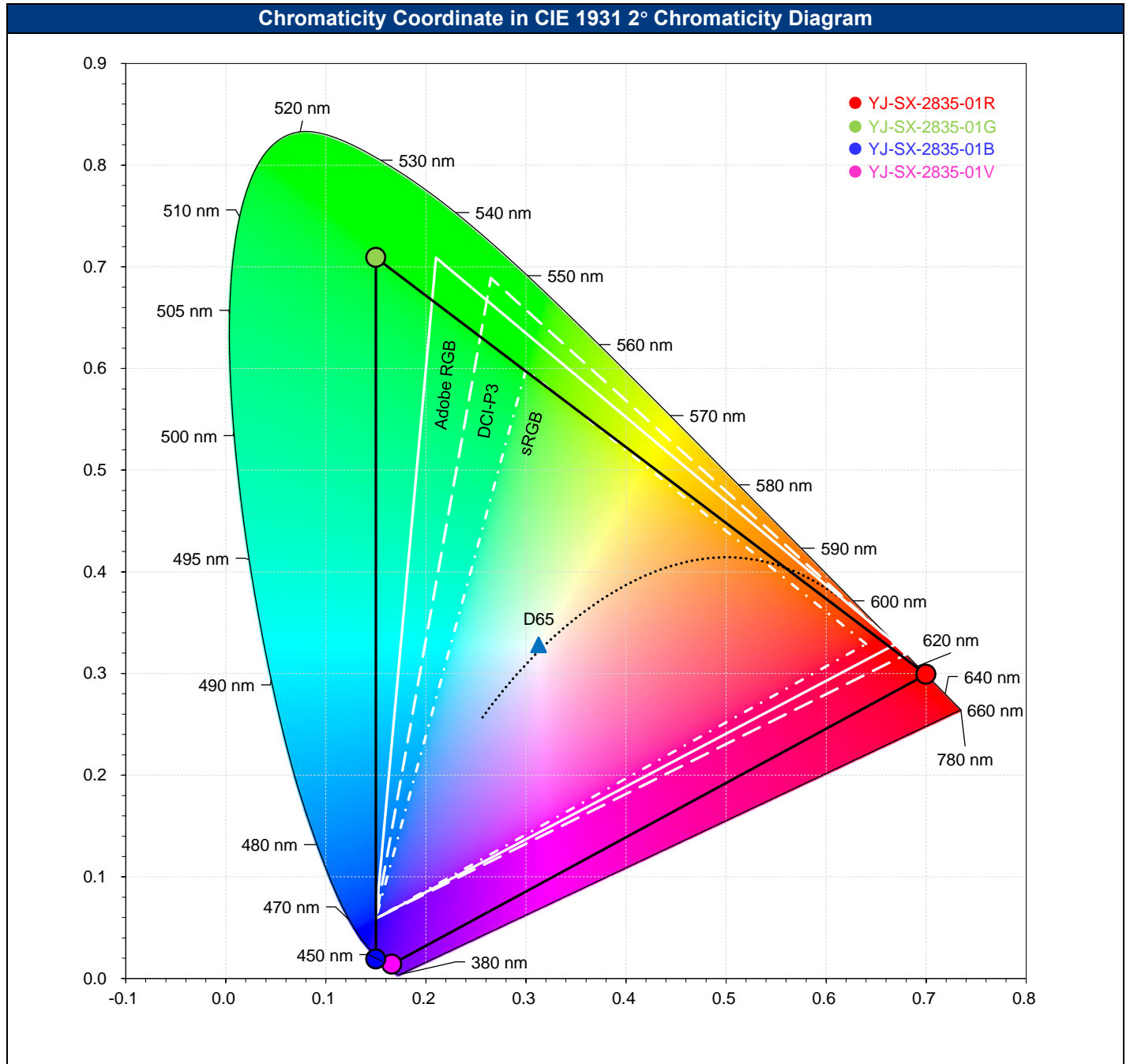

PACKAGE LAYOUT

All dimensions in mm, tolerance unless mentioned is ± 0.1 mm.

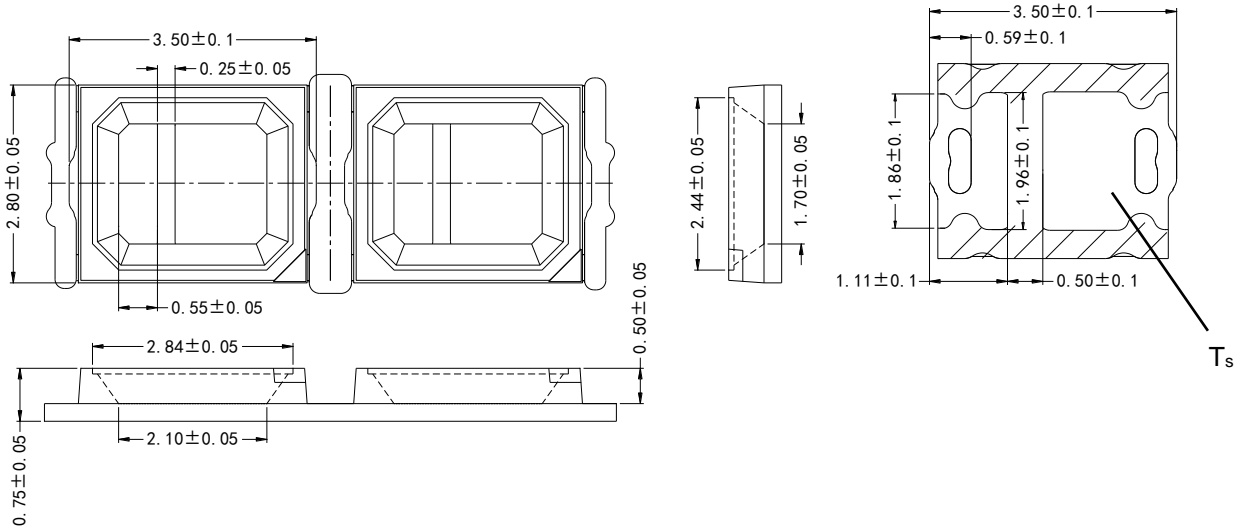

PACKAGE MATERIALS

ITEM	DESCRIPTION
DIE MATERIAL	AlGaInP
LEAD FRAME MATERIAL	PPA
ENCAPSULANT RESIN MATERIAL	SILICONE
ELECTRODES MATERIAL	SILVER-PLATED COPPER

RECOMMENDED SOLDER PAD LAYOUT

All dimensions in mm, tolerance unless mentioned is ± 0.1 mm.

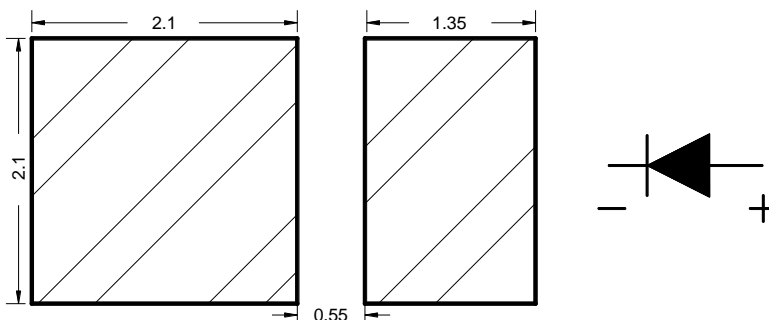

CHARACTERISTIC CURVES

ALL CHARACTERISTIC CURVES ARE FOR REFERENCE ONLY AND NOT GUARANTEED

FORWARD CURRENT VS FORWARD VOLTAGE ($T_A = 25^\circ\text{C}$)

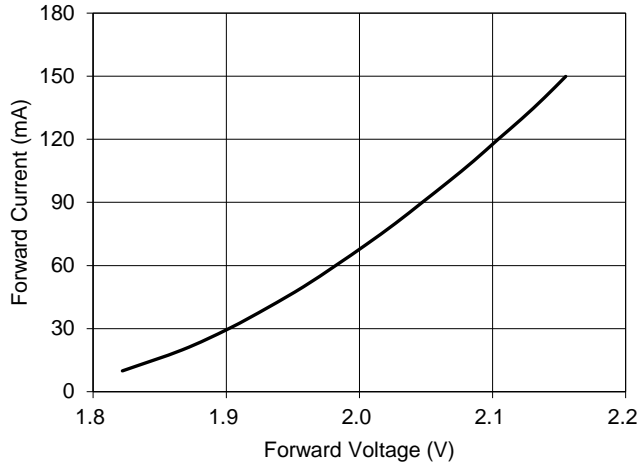

FORWARD CURRENT VS RELATIVE LUMINOUS OUTPUT ($T_A = 25^\circ\text{C}$)

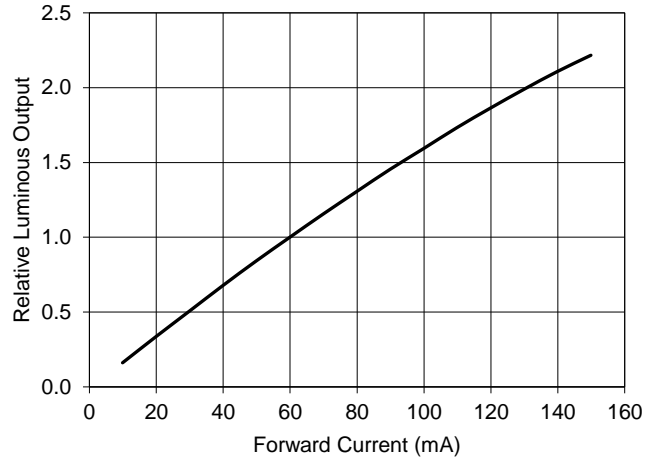

SOLDER POINT TEMPERATURE VS FORWARD VOLTAGE ($I_F = 60\text{ mA}$)

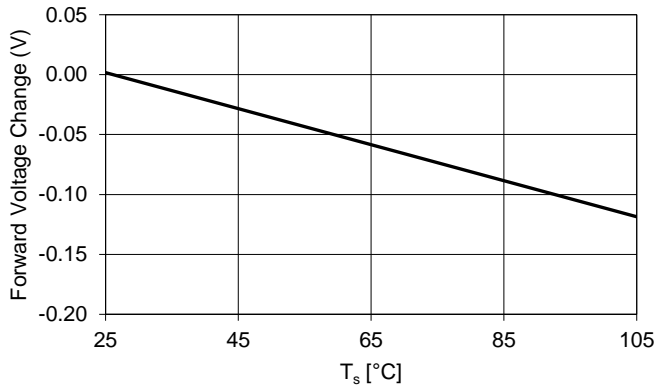

SOLDER POINT TEMPERATURE VS RELATIVE LUMINOUS OUTPUT ($I_F = 60\text{ mA}$)

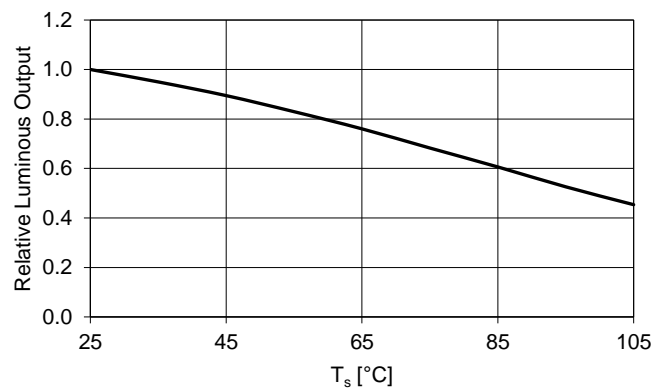

FORWARD CURRENT VS DOMINANT WAVELENGTH ($T_A = 25^\circ\text{C}$)

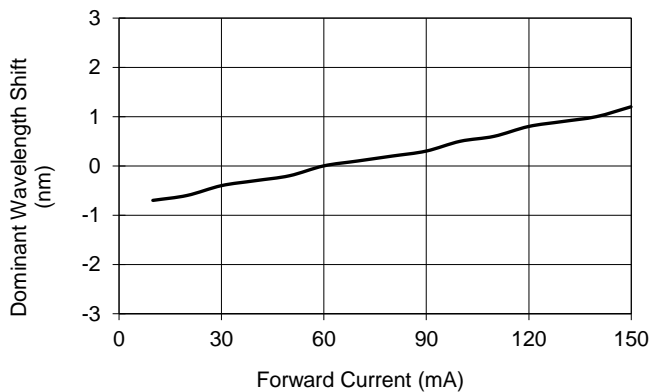

SOLDER POINT TEMPERATURE VS DOMINANT WAVELENGTH ($I_F = 60\text{ mA}$)

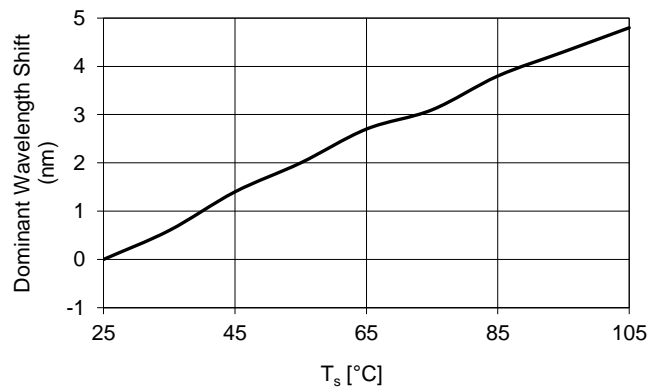

CHARACTERISTIC CURVES (CONTINUED)

FORWARD CURRENT DERATING BASED ON SOLDER POINT

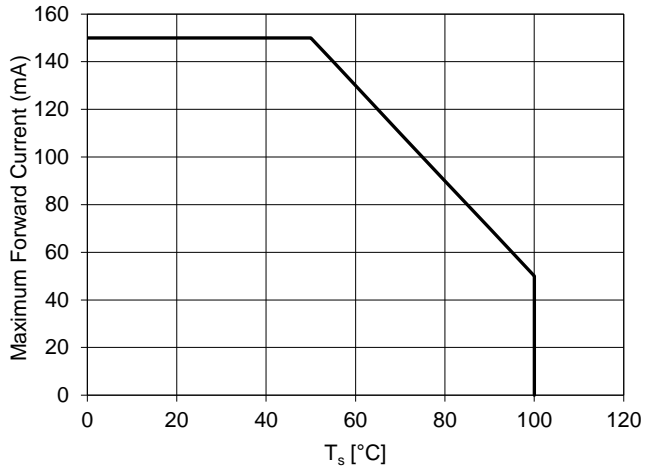

NOTE: DE-RATING CURVES ARE MEANT FOR RECOMMENDATION ONLY AND ARE NOT MEANT TO PROVIDE GUARANTEES OF PRODUCT STABILITY AND LONGEVITY

TYPICAL SPATIAL DISTRIBUTION
 ($T_A = 25^\circ\text{C}$, $I_F = 65\text{ mA}$)

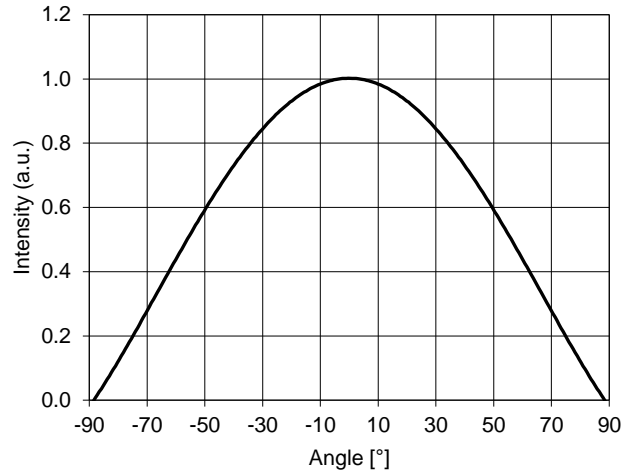

TYPICAL SPECTRAL DISTRIBUTION GRAPHS

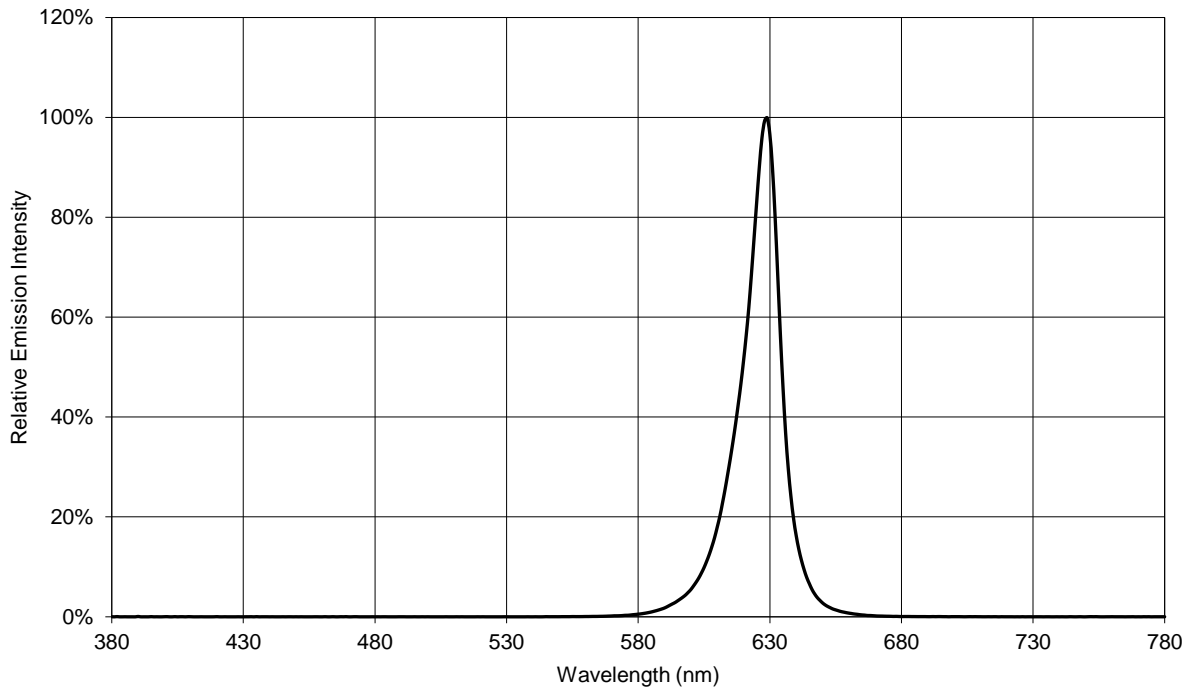

REFLOW PROFILE

SOLDERING RAMP-UP TIME (Pb-FREE)

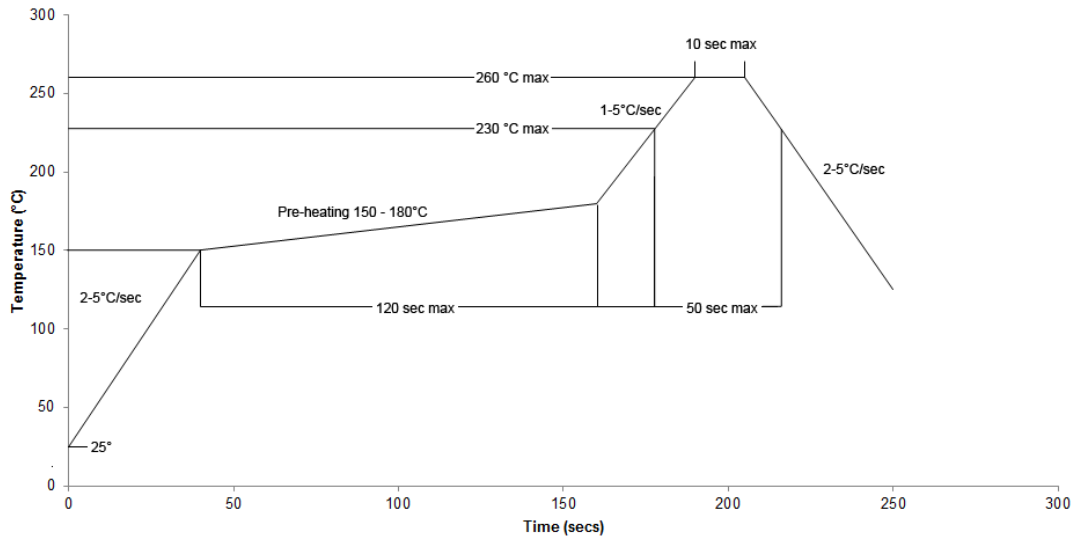

NOTE: Soldering paste with the melting point at 230°C is recommended

INSTRUCTIONS FOR SMT

Problems caused by improper selection of collet

Choosing the right collet is important in ensuring product quality after SMT. LEDs are different from other electronic components, as they are not only concerned with electrical output but also optical output. This characteristic makes LEDs more fragile in the process of SMT. If the collet's lowering height is not well set, it will bring damage to the gold wire at the time of collet's pick-and-place process which can cause the LED to not illuminate, flicker or contribute to other quality problems, some of which may not be immediately detectable.

Collet selection

During SMT, please choose the collet that has larger outer diameter than the lighting area of lens, in order to avoid damage the gold wire inside the LED. Different collets fit for different products, please refer to the following figures below.

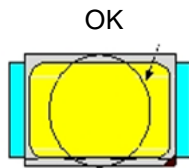

NOT OK – COLLET TOO SMALL

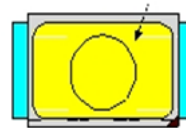

Setting the height of the collet is crucial in order to avoid damage to the top view SMD. If the collet setting is set to too low of an altitude, the collet will press down on the SMD, causing damage or breakage to the encapsulant and cause distortion or breakage of the gold wire.

Other notes of caution:

- No pressure should be exerted to the epoxy shell of the SMD under high temperature.
- Do not scratch or wipe the lens since the lens and gold wire inside are rather fragile and cross out easy to break.
- LED should be used as soon as possible when being taken out of the original package, and should be stored in anti-moisture and anti-ESD package.
- This usage and handling instructions are for reference only.

TAPE SPECIFICATIONS

TAPE DIMENSIONS (UNIT: MM)

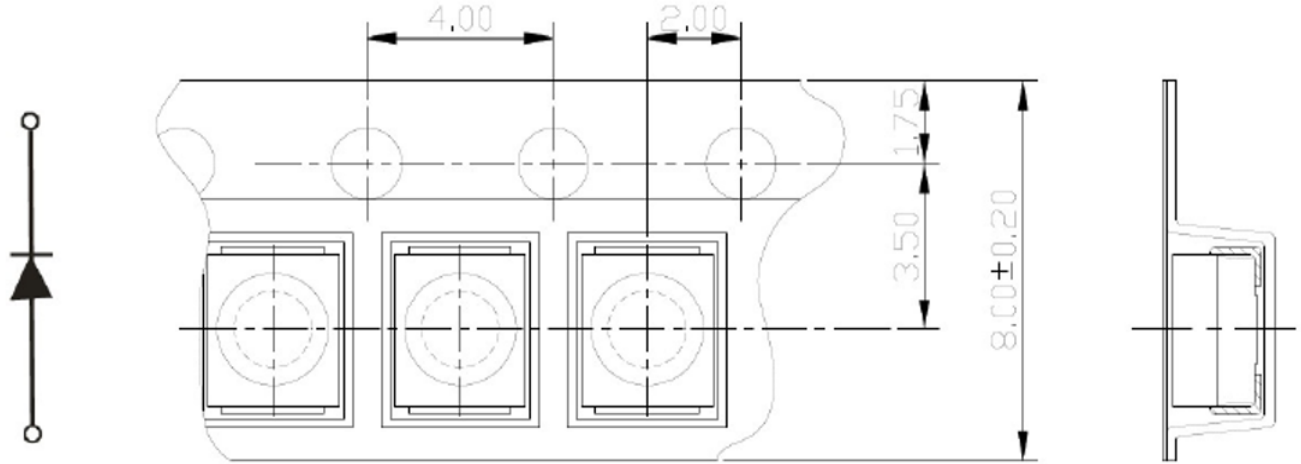

All dimensions in mm, tolerance unless mentioned is ± 0.1 mm.

TAPE LAYOUT (NOT DRAWN TO SCALE)

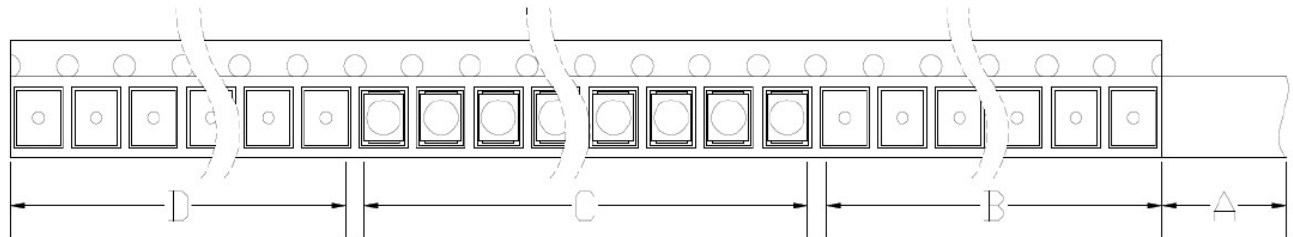

- A: COVER TAPE, 300 MM;
- B: EMPTY LEADER, 200 MM;
- C: LED, 3000 PCS;
- D: EMPTY TRAILER, 200 MM;

REEL SPECIFICATIONS

REEL DIMENSIONS TOP (UNIT: MM)

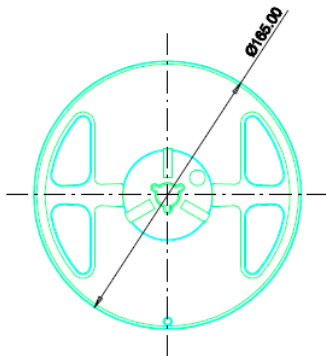

REEL DIMENSIONS BOTTOM (UNIT: MM)

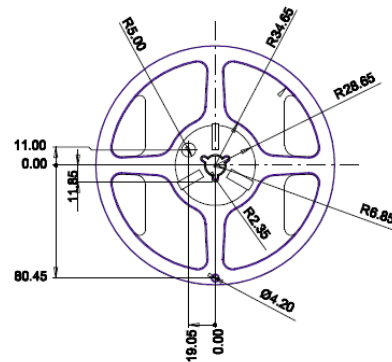

REEL DIMENSIONS SIDE (UNIT: MM)

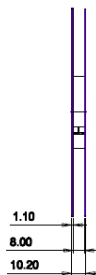

FEEDING DIRECTION

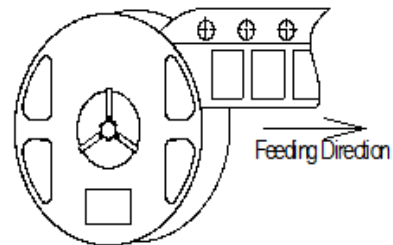

LOT NUMBERING SCHEME

Yuji LED uses two formats for lot numbering purposes:

1) YYYY-MM-XXX-Z

YYYY: 4-digit manufacturing year
 MM: 2-digit manufacturing month
 XXX: 3-digit inventory number (000 – 999)
 Z: internal alphanumeric code

2) YYYYMMXXX

YYYY: 4-digit manufacturing year
 MM: 2-digit manufacturing month
 XXX: 3-digit inventory number (000 – 999)

SHIPPING INFORMATION

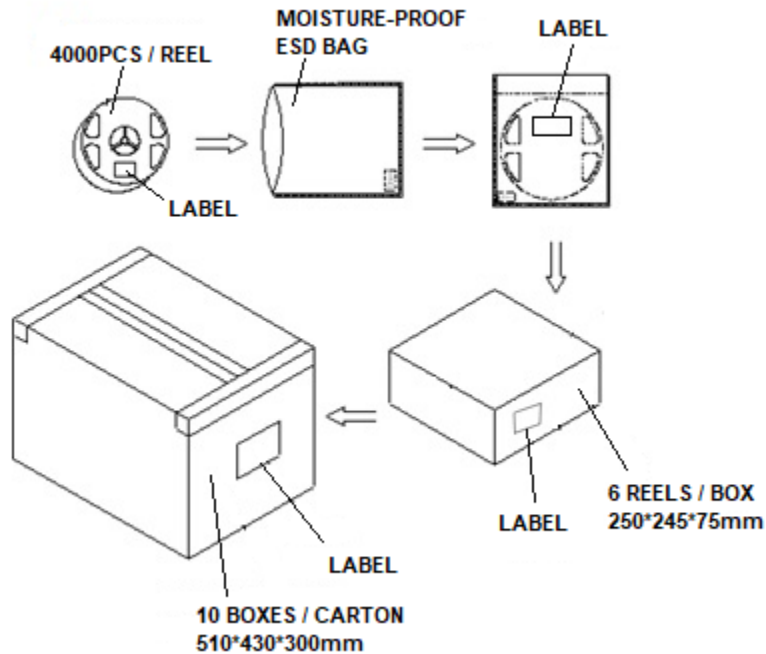

NOTES:

1. Reeled products (max 4,000 pcs / reel) are packed in a moisture-proof bag along with a moisture desiccant pack.
2. Each inner box contains up to 6 moisture-proof bag (total maximum number of SMDs is 24,000pcs). Box package size: 250 mm x 245 mm x 75 mm.
3. Each outer package contains 10 inner boxes. Box size: 510 mm x 430 mm x 300 mm.
4. Outer package is sealed with protective bubble wrap and foam. (Part numbers, lot numbers, quantity should appear on the label on the moisture-proof bag, part numbers).
5. This packaging merely intended as a reference for standard quantity orders only – please note that actual packaging can differ depending on the order circumstances.