

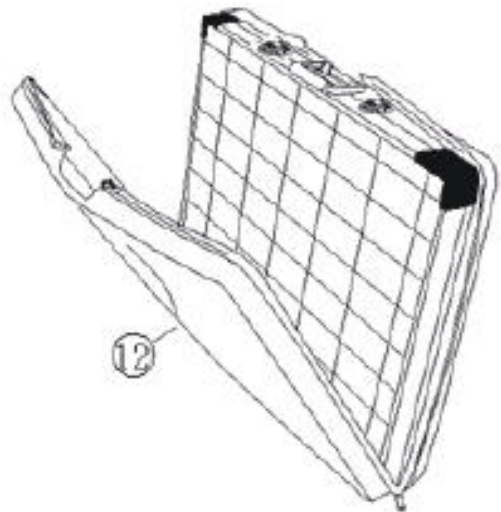

PTK-100LCD10A

# User Manual

# Summary of folding solar panel structure

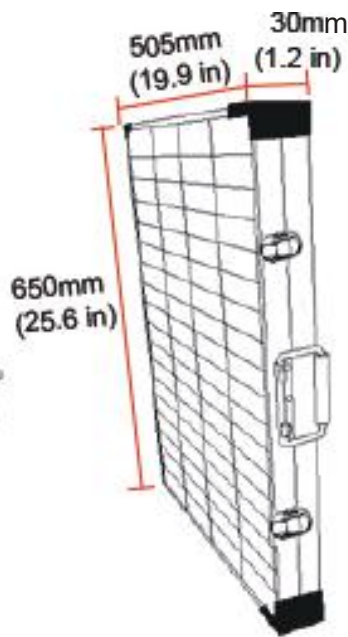

*Power Your Green Life!*

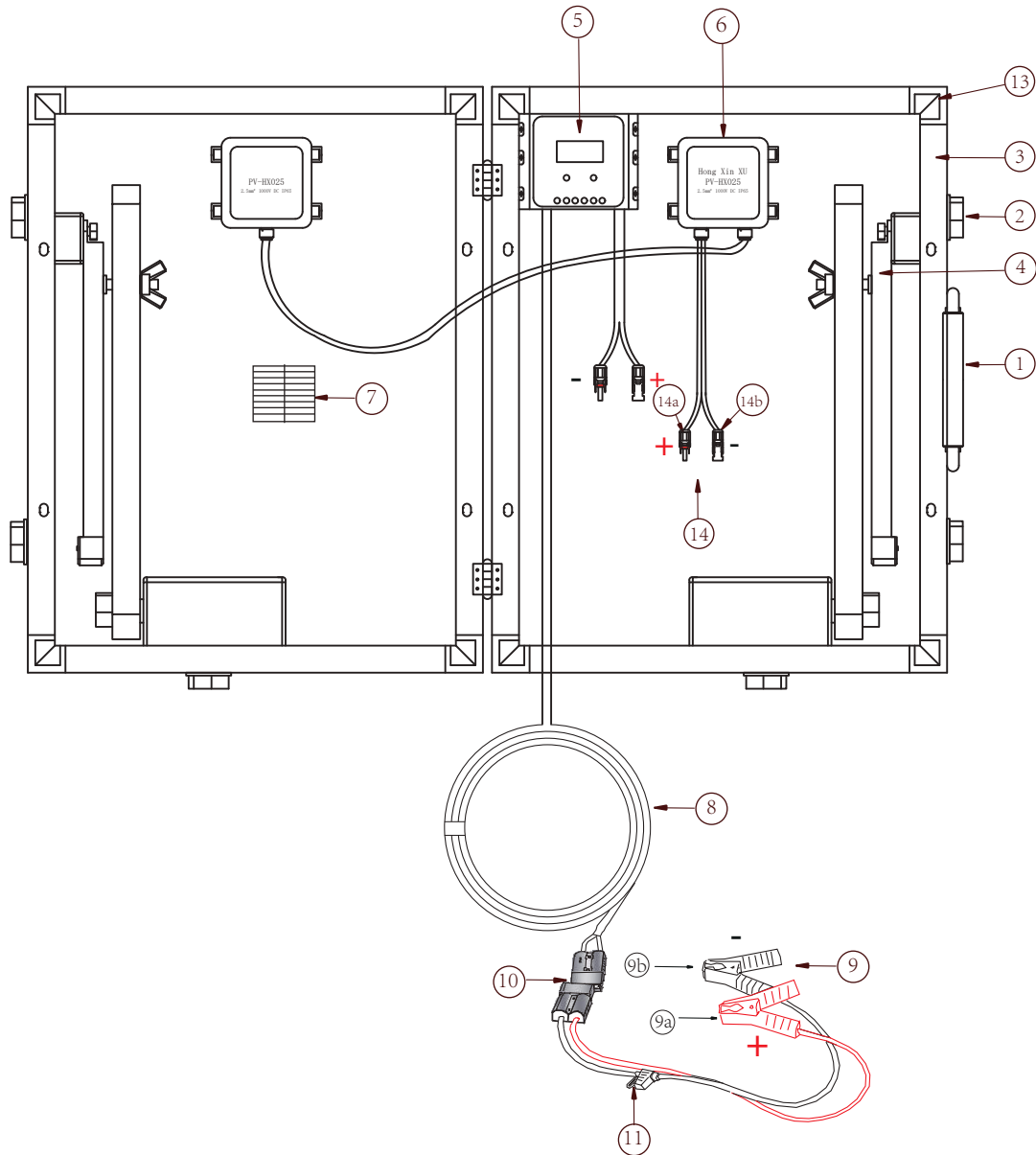

## Accessories:

1. Handle	9a. Red Positive Battery Clip
2. Latches	9b. Black Negative Battery Clip
3. Aluminum frame	10. Anderson Plug
4. Aluminum support legs	11. Fuse
5. Solar charge controller	12. Handy carry bag
6. Junction box	13. Corner protector
7. Label	14. MC4 cables
8. Cable	14a. Red Positive MC4 Cable
9. Battery Clips	14b. Black Negative MC4 Cable

*Power Your Green Life!*

## Introduction

This portable solar panel comes with a pre-installed charge controller. This charge controller protects the battery against unsafe electrical conditions and must be used to charge 12V batteries. To charge solar generators with a built-in charge controller, simply use the MC4 cables provided and plug them into the cables that came with your power station to charge. A 12V battery and solar generator can be charged at the same time.

## Features

- Max 100 watts solar panel
- 10A PWM charge controller
- Portable
- Removable MC4 Connectors
- Charge 12V battery by alligator clamps- Sealed, Flooded, GEL, AGM, Lithium and other deep cycle batteries
- Charge 12V solar generator by MC4 adapter- battery with inverter, power bank/station with built-in charge controller. ACOPOWER solar generator 150wh and 220wh recommended
- Can be used on its own or as part of a larger solar system
- Extendable with MC4 Connectors

## User's guide

After receiving the solar panel kit, please check if all accessories are included in the package and prepare to test your kit:

1. Locate a sunlit area clear from hanging branches or obstacles.
2. Unclip the two latches (2, Table 1) on the side of the unit and fold two panels outward. Extend the two support legs (4, Table 1) to desired length and lock the stands in position. Set solar panel kit in the position facing the sun.

**Tip:** To obtain the maximum output power of solar modules, it is recommended to adjust the solar modules based on solar trajectory.

## How to test the solar panel

Method 1: Use a multimeter

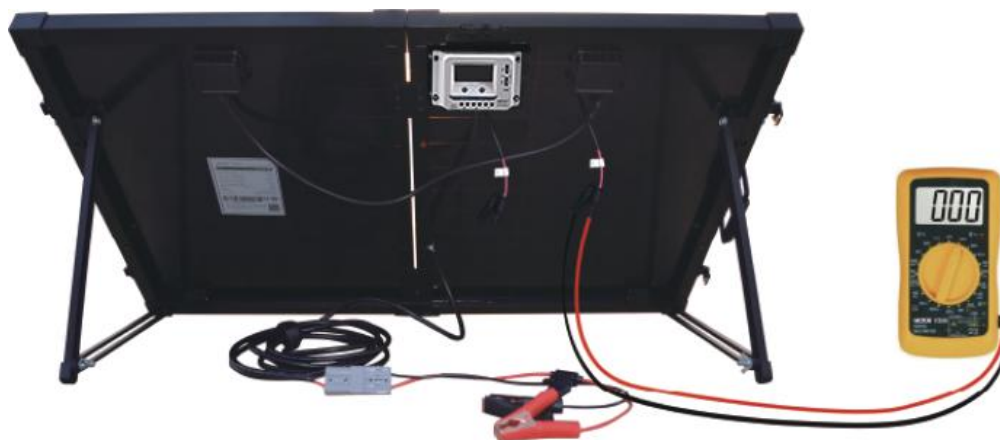

Set your multi-meter to measure DC voltage and put the red probe on the red positive MC4 cable (14a, Table 1) and the black probe on the black MC4 cable (14b, Table 1) and make sure the connections are secure. the open-circuit voltage should be displayed on your multi-meter and it should be around 17.6V-23V. This is your solar panel's voltage without going through the charge controller.

*Power Your Green Life!*

If you're not getting something within that range or close to those numbers, you should check and make sure the solar panel is in direct sunlight and that the connections between the MC4 cables and the multi-meter is secure.

Method 2: Use your solar generator



To test if the solar panel is working with a solar generator with a built-in charge controller, connect the MC4 adapters that came with your solar generator and plug it in to the MC4 cables of the solar panel directly (14a and 14b, Table 1). Turn your solar generator on and it should start charging from the solar panel.

## How to test if the charge controller is working



Choose: GEL、Flooded、Sealed

**When testing the charge controller, please make sure a battery in working condition is used. The charge controller will not power on with a bad battery. A good thing to do is to test with your 12 V car battery.**

Step 1: Clamp the red positive battery clip (9a, Table1) to the positive terminal of 12V battery, black negative battery clip (9b, Table 1) to the negative terminal and make sure the connection is secure.

Step 2: When all the connections are complete, the LCD Display of the charge controller should light up if the battery is connected correctly. If the solar panel is under direct sunlight, the charging status indicator (Figure 3) will be on as well. (Detailed information under Charge Controller section)

**Tip: The charge controller will not respond unless it is connected to a battery!** Always connect the battery first, then load (if applicable).

For details on controller operation, please check the Charge Controller section.

*Power Your Green Life!*

## What are you going to use it for

### 1. Charge solar generators

#### 1.1. Charge 12V Solar Generator with built-in Charge Controller



Step 1: understand your solar generator and prepare the MC4 adapter for your solar generator

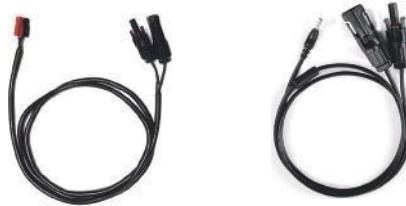

Step 2: Disconnect MC4 Connectors and let it to be a solar panel with MC4 connectors  
 Step 3: Use your MC4 Adapter to charge your solar generator

### 2. Charge your 12 Volt battery

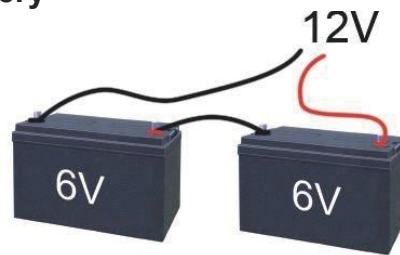

The solar panel kit is designed to charge a large range of batteries including Sealed, Flooded, GEL, AGM, Lithium, lead-acid battery and other deep cycle battery. The batteries are used as car battery, RV battery, boat battery and emergency back-up battery.

Step 1: understand your battery: battery type, capacity and voltage

Step 2: check the charge controller's set up. We have defaulted the setting of the charge controller is for SEALED. (AGM is also included in SEALED type.) If your battery's type is different, please set your battery type with the charge controller following the instructions below.

### 3. Connect in parallel with another solar panel to charge a 12V battery faster

When you combine two solar panels in parallel, the current from the two solar panels are added together and this will enable the battery to charge faster. For more information about adapters needed, please contact us.

**Warning: Make sure the combined current is lower than the rated current of the charge controller which is 10 amps for this model**

*Power Your Green Life!*



## PV Specifications

### 100w solar panel

	Type	Module Size	N.W	Specification				
				Max-Power	MaxPower Voltage	Max-power Current	Open-Circuit Voltage	Short-circuit Current
	Module	mm	Kg	W	V	A	V	A
	2*50w	650*505*30 (25.6*19.9*1.2 in)	15 (33.1 lb)	2*50	17.8	2*1.8 1	22 .3	2*3.03

## Charge Controller

This solar panel module comes with a 10A solar charge controller which will look like the one shown below. (colors may vary)

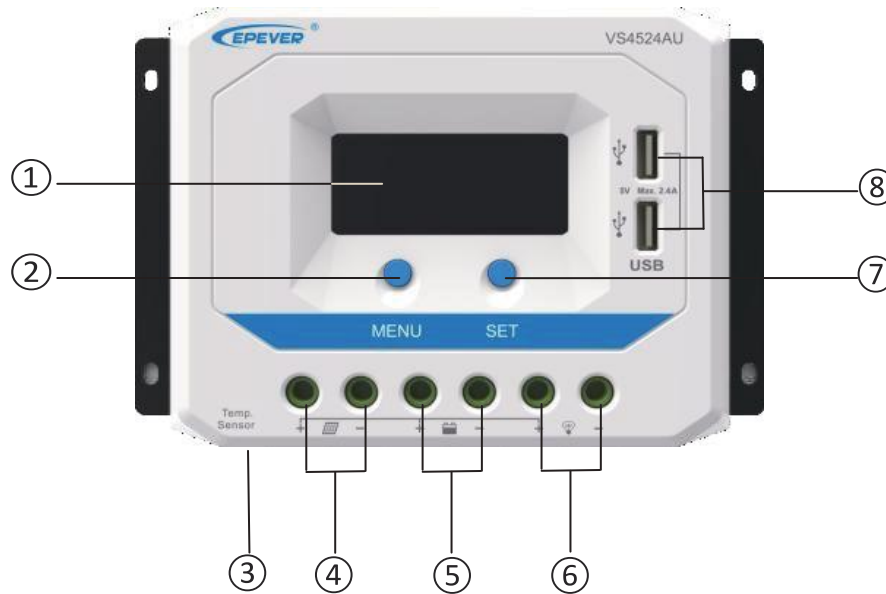

①	LCD	⑤	Battery Terminals
②	MENU Button	⑥	Load Terminals
③	RTS Port	⑦	SET Button
④	PV Terminals	⑧	USB Output Ports✳

*Power Your Green Life!*

## Wiring

Connect all components as shown in "Figure 1: Connections" in this order:

1. Battery
2. Load
3. PV Array

() Always connect the battery first. The charge controller does not come with independent power and will not power on without first being supplied power from the battery. This also allows it to recognize the system voltage for proper setup. When disconnecting the system, do in reverse order.

() Pay close attention to the polarity "+" and "-" of your connections. Do not insert the fuse or turn on the breaker during installation.

() Connect the battery fuse as close to the battery as possible. Recommended no more than 150mm from the battery terminal

() The VS AU series is a positive ground charge controller. Any positive connection of solar or battery can be earth grounded.

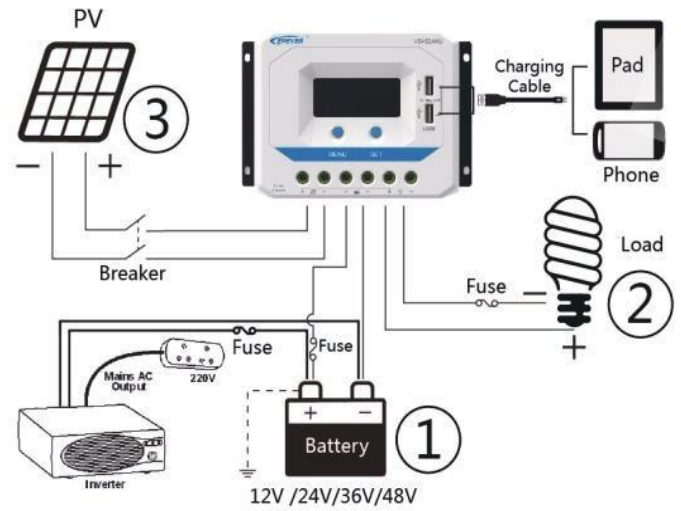

Figure 1: Connections

## Installation & Operation

Figure 2: Button functions

Button	Function
MENU button	<ul style="list-style-type: none"> <li>• Browse interface</li> <li>• Setting parameter</li> </ul>
SET button	<ul style="list-style-type: none"> <li>• Load ON/OFF</li> <li>• Clear error</li> <li>• Enter into Set Mode</li> <li>• Save data</li> </ul>

() When not operating the LCD interface, the controller will cycle through the shown interfaces in Figure 4. These interfaces can be cycled through manually by pressing the MENU button.

() Accumulative Power Zero Clearing: Under PV Power interface, Press the SET button and hold for 5s until the value blinks. Press SET again to clear the value:

() Setting temperature unit: Under battery temperature interface, press SET button and hold for 5s to switch.

Item	Icon	Status
PV array		Day
		Night
		No charging
		Charging
Battery		PV Voltage, Current, Power
		Battery capacity, In Charging
		Battery voltage, current, temperature
Load		Battery type
		Load ON
		Load OFF
		Load Voltage, Current, Load mode

Figure 3: Status Description

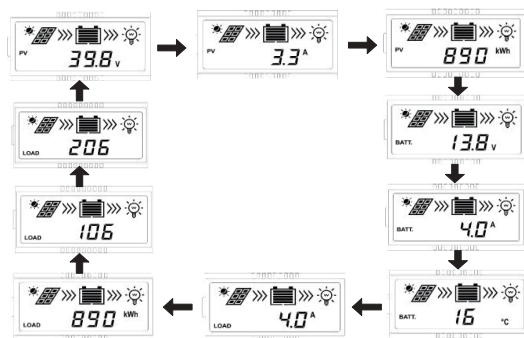

Figure 4: LCD Interface

## Fault Indications

() When load current reaches 1.02-1.05 times, 1.05-1.25 times, 1.25-1.35 times and 1.35 to 1.5 times more than normal value, the controller will automatically turn off loads in 50s, 30s, 10s, and 2s respectively

**Note: A Remote Temperature Sensor (RTS) is an optional accessory. The charge controller will not track battery temperature without an RTS. Controller shows fixed 25 C with no RTS.**

Status	Icon	Description
Battery over discharged		Battery level shows empty, battery frame blink, fault icon blink
Battery over voltage		Battery level shows full, battery frame blink, fault icon blink





## Load mode Settings

() Under load mode setting interface, press SET button and hold for 5s until the number begins flashing. Then press MENU button to set the parameter, press SET to confirm. Refer to Figure 5 below for load modes.

***	Timer 1	2**	Timer 2
100	Light ON/OFF	2 n	Disabled
101	Load will be on for 1 hour since sunset	201	Load will be on for 1 hour before sunrise
102	Load will be on for 2 hours since sunset	202	Load will be on for 2 hours before sunrise
103~113	Load will be on for 3~13 hours since sunset	203~213	Load will be on for 3~13 hours before sunrise
114	Load will be on for 14 hours since sunset	214	Load will be on for 14 hours before sunrise
115	Load will be on for 15 hours since sunset	215	Load will be on for 15 hours before sunrise
116	Test mode	2 n	Disabled
117	Manual mode(Default load ON)	2 n	Disabled

Figure 5: Load Modes

Battery Overheating (Requires RTS)		Battery level shows current value, battery frame blink, fault icon blink
Load failure		Load overload, Load short circuit

Note: Please set Light ON/OFF, Test mode and Manual mode via Timer 1. Timer2 will be disabled and display "2 n".

## Setting Battery Type

() Under Battery Voltage Interface, press SET button and hold for 5s, then enter the interface of Battery Type setting. Choose your battery type by pressing the MENU button. Press SET to confirm the battery type or wait 5s to auto confirm.

Note: Please refer to the battery voltage parameters table for the different battery types.

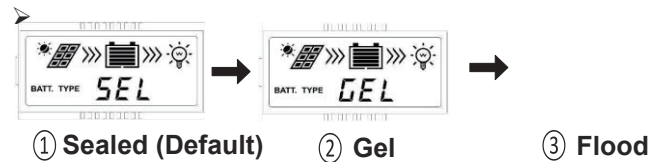

## Troubleshooting

Refer to the tables below for common troubleshooting issues. Figure 6 Shows the included protections with the charge controller while Figure 7 Shows some common troubleshooting applications.

Protection	Conditions	Status
PV Reverse Polarity	When the battery is connected correctly, the PV Polarity may be reversed	The Controller is not damaged. The error must be corrected.
Battery Reverse Polarity	When the PV is not connecting, the battery polarity can be reversed	
Battery Over Voltage	The battery voltage reaches to the OVD	Controller stops charging
Battery Over Discharge	The battery voltage reaches the LVD	Controller stops discharging
Battery Overheating (Requires RTS)	Temp. Sensor is higher than 65 C	Output is OFF
	Temp. Sensor is less than 55	Output is ON
Controller Overheating	Temp. Sensor is higher than 85 C	Output is OFF
	Temp Sensor is less than 75 C	Output is ON
Load Short Circuit	Load current $\geq 2.5$ times rated current One short circuit, the output is OFF 5s ; Two short circuit, the output is OFF 10s ; Three short circuit, the output is OFF 15s ; Four short circuit, the output is OFF 20s ; Five short circuit, the output is OFF 25s ; Six short circuit, the output is OFF	Output is OFF; <b>Clear the fault:</b> Restart the controller or wait for one day-night cycle (night time>3 hours)
Load Overload	Load current $\geq 2.5$ times rated current 1.02-1.05 times, 50s, 1.05-1.25 times, 30s 1.25-1.35 times, 10s 1.35-1.5 times 2s	Output is OFF; <b>Clear the fault:</b> Restart the controller or wait for one day-night cycle (night time>3 hours)
Damaged RTS	The RTS is short-circuited or damaged	Controller shows constant 25 C (NOT actual temp.)

Figure 6: Protections





Faults	Possible Reasons	Troubleshooting
The LCD is off during daytime when sunshine falls on PV modules properly	PV array disconnected	Confirm that PV wire connections are correct and tight
Wire connection is correct, LCD not displaying	1) Battery voltage is lower than 9V 2) PV Voltage is less than battery voltage	1) Check the voltage of the battery. At least 9v is required to activate the controller. 2) Check PV input voltage which should always be higher than battery's
 Interface Blink	Battery over voltage	Disconnect the PV. Check if the battery voltage is higher than OVD (over voltage disconnect) Point.
 Interface Blink	Battery over discharged	When the battery voltage is restored to or above LVR (Low voltage reconnect) Point, the load will recover.
 Interface Blink (Requires RTS)	Battery overheating	The controller will automatically turn off the system. When temperature declines to 50 C, the controller will resume
 Interface Blink	Over load or Short circuit	Please reduce the number of electric equipments or check carefully the loads connection.

Figure 7: Troubleshooting

Power Your Green Life!

## Charge Controller Specifications

Refer to the table below for technical specifications of our charge controllers.

Item	VS1024AU	VS2024AU	VS3024AU	VS3048AU	VS4524AU	VS4548AU	VS6024AU	VS6048AU
Nominal system voltage	12/24VDC Auto			12/24/36/48 VDC Auto	12/24VDC Auto	12/24/36/ 48VDC Auto	12/24VD C Auto	12/24/36/48V DC Auto
Battery input voltage range	9V~32V			9V~64V	9V~32V	9V~64V	9V~32V	9V~64V
Rated charge/discharge current	10A@55°C	20A@55°C	30A@55°C		45A@55°C		60A@55°C	
Max. PV open circuit voltage	50V			96V	50V	96V	50V	96V
Battery type	Sealed(Default) / Gel / Flooded							
Equalize Charging Voltage※	Sealed:14.6V/ Gel: No/ Flooded:14.8V							
Boost Charging Voltage※	Sealed:14.4V/ Gel:14.2V/ Flooded:14.6V							
Float Charging Voltage※	Sealed/Gel/Flooded:13.8V							
Low Voltage Reconnect Voltage※	Sealed/Gel/Flooded:12.6V							
Low Voltage Disconnect Voltage※	Sealed/Gel/Flooded:11.1V							
Self-consumption	≤9.2mA/12V;≤11.7mA/24V; ≤14.5mA/36V;≤17mA/48V							
Temperature compensation coefficient	-3mV/°C/2V (25°C)							
Charge circuit voltage drop	≤0.29V							
Discharge circuit voltage drop	≤0.16V							
LCD temperature range	-20°C~+70°C							
Working environment temperature	-25°C~+55°C(Product can work continuously at full load)							
Relative humidity	≤95%, N.C.							
Enclosure	IP30							
Grounding	Common Positive							
USB output	5VDC/2.4A(Total)							
Overall dimension	142x85x41.5mm	160x94.9x49.3mm	181x100.9x59.8mm		194x118.4x63.8mm		214x128.7x72.2mm	
Mounting dimension	130x60mm	148x70mm	172x80mm		185x90mm		205x100mm	
Mounting hole size	Φ4.5mm		Φ5mm		Φ5mm		Φ5mm	
Terminals	4mm <sup>2</sup> /12AWG	10mm <sup>2</sup> /8AWG	16mm <sup>2</sup> /6AWG		16mm <sup>2</sup> /6AWG		25mm <sup>2</sup> /4AWG	
Net weight	0.22kg	0.35kg	0.55kg	0.58kg	0.76kg	0.88kg	1.02kg	1.04kg
※Above the parameters are in 12V system at 25°C, twice in 24Vsystem, triple in 36V system and quadruple in 48V system.								

### Disclaimer: Warranty does not apply under the following conditions

- 1) Damage from improper use or use in an unsuitable environment
- 2) PV or Load current, voltage or power exceeding the rated value of the charge controller
- 3) The controllers working temperature exceeds the limit working environment temperature
- 4) User disassembly or attempted repair of the charge controller without permission
- 5) The controller is damaged due to natural elements such as lightning
- 6) The controller is damaged during transportation and shipment

**Please contact technical support for any questions or troubleshooting errors you may have!**

*Power Your Green Life!*

## FREQUENTLY ASKED QUESTIONS (FAQ)

ACOPOWER is always open to customers with technical support, if you have any issues, please feel free to contact ACOPOWER by email at [support@acopower.com](mailto:support@acopower.com)

Here we collected some frequently asked questions for reference:

Q: What type of batteries can be used with the kit?

A: 1. sealed lead-acid battery (Sealed) 2. colloidal lead-acid battery (Gel) 3. the opening lead-acid batteries (Flooded)

Q: How to clean the solar panel surface?

A: When dust and dirt cover the surface of solar module, it can be cleaned with a soft brush, then use a damp cloth to wipe the surface to remove the remaining dust and dirt. Anything that covers the solar cells should be removed as soon as possible so as not to affect performance.

Q: Are the foldable solar modules waterproof?

A: Because the system contains sophisticated electronic components, please prevent water from contacting the module during use.

Q: How can I get my battery's information?

A: To get your battery's information, please contact your battery's manufacturer or check your battery label.

Q: Is the charge controller waterproof, what is IP rate for that?

A: No, the charge controller is not waterproof.

Q: Can I use extension cables in the system?

A: Yes, any extension cable with MC4 connectors can be used before the solar charge controller. ACOPOWER has 20ft 14AWG extension cables.

Q: How do I get the MC4 Adapter for my solar generator?

A: Please contact your solar generator's seller or manufacturer to get a MC4 adapter. The MC4 is a solar industrial universal connector. If your solar generator's supplier does not provide it, please contact ACOPOWER to get it customized.

Q: It worked for my car battery but it does not charge my solar generator.

A: Please check your solar generator's connection and voltage. Some generators in the market are designed to be unique like 24V battery. Most solar generators in the market is 12V. Please contact your solar generator's supplier for the voltage confirmation.

Q: My battery is two 6V batteries in series, can I use this kit?

A: Yes. Two 6V batteries in series is considered a 12 Volt battery.

Q: My battery is AGM, which battery setting shall I use?

A: Please use SEALED, which is default setting.

Q: My battery is lithium battery, which battery setting shall I use?

A: please use FLOODED.

Q: Will the system discharge my battery after sunset?

A: No. The charge controller avoids discharging from battery.

*Power Your Green Life!*

Q: Can I use my own controller, or can I use MPPT charge controller?

A: Yes, if you would like to do so, please remove the charge controller and use the solar panel with MC4 connectors to connect your own controller.

Q: I connect the kit with my battery with red clamp to Positive and black clamp to Negative, why won't the charge controller power on?

A: We suggest charging your car battery for the kit's test. Test your solar panel's open circuit voltage and battery's voltage. If the solar panel open circuit voltage is good and the battery's voltage is lower than rechargeable voltage, the battery should be recharged some other way or replaced before charging with the solar panel.

Q: Can I use the solar panel to jumpstart a drained battery?

A: No, a drained car battery has lower voltage than what the kit could recharge. Therefore, please jump start the battery and make sure the battery is high enough, then charge it by the solar panel.

Q: Can I use the solar panel to avoid my battery drain?

A: Yes.

Q: My RV has a Zamp solar plug or other types of plugs, how do I use this solar panel kit?

A: You will need to refer to the RV user manual and find out what kind of adapter you may need. Most adapters are sold on Amazon. Please contact [support@acopower.com](mailto:support@acopower.com) if you can't find what you need.

Q: The solar panel kit has the correct voltage reading but it won't charge my generator.

A: Please check the voltage rating of your generator, it might be rated at 24V and this solar panel kit is only for charging 12V batteries. Another possibility is that the generator is already fully charged.

## Safety Tips

- **Before using the product, read all safety precautions**
- **If the product is abnormal or damaged, do not use**
- **Do not allow water to enter the controller**
- **Prevent sharp objects from impacting the surface of solar modules**
- **Ensure proper battery clip connection to prevent short circuits**
- **No user license serviceable parts inside. Do not disassemble or attempt to repair it**
- **Do not touch the exposed electrical conductor of the battery**

*Power Your Green Life!*

## Warranty

### **Limited Product Warranty-One Years Repair, Replacement and refund Remedy, but fuse excluded**

The solar panel itself comes with an 18-months workmanship warranty and a 25-year 85% output warranty.

Within 30 days of purchase: Items can be returned for a full refund or replacement, we will cover return shipping due to quality issues, buyer pays return shipping and replacement shipping due to non-quality issues.

Within 30 days to 6 months: Items can be replaced new or refurbished due to quality issues, we will cover return shipping. Items can be replaced with a restocking fee due to non-quality issues, buyer pays for all shipping.

Within 6 months to 18 months: Items can be replaced refurbished due to quality issues, buyer pays for all shipping.

Accessories:

Within 30 days of purchase: Items can be returned for a full refund or replacement, we will cover return shipping due to quality issues, buyer pays return shipping and replacement shipping due to non-quality issues.

Within 30 days to 6 months: Items can be replaced new or refurbished due to quality issues, we will cover return shipping. Items can be replaced with a restocking fee due to non-quality issues, buyer pays for all shipping.

Within 6 months to 18 months: Items can be replaced refurbished due to quality issues, buyer pays for all shipping.

Charge Controller: The controller itself comes with a 1-year warranty.

Within 30 days of purchase: Items can be returned for a full refund or replacement, we will cover return shipping due to quality issues, buyer pays return shipping and replacement shipping due to non-quality issues.

Within 30 days to 6 months: Items can be replaced new or refurbished due to quality issues, we will cover return shipping. Items can be replaced with a restocking fee due to non-quality issues, buyer pays for all shipping.

Within 6 months to 1 year: Items can be replaced refurbished due to quality issues, buyer pays for all shipping.

Seller shall not be responsible or liable in any way to the customer or any third-party arising from any non-performance or delay in performance of any terms and conditions of sale, including this "Limited Warranty for PV Modules", due to acts of God, war, riots, strikes, warlike conditions, plague or other epidemics, fire, flood, or any other similar cause or circumstance beyond reasonable control. such cases, this Limited Warranty shall be suspended without liability for the period of delay reasonably attributable to such causes.

Register your warranty with ACOPWER, please visit: <https://www.acopower.com> select "Warranty Registration".

*Power Your Green Life!*

Thank you for your business and support!

ACOPower Team

technical support: [support@acopower.com](mailto:support@acopower.com) [www.acopower.com](http://www.acopower.com)



Warranty Registration Web

*Power Your Green Life!*